

Ingersoll Rand Reduced Swing Doorset

Technical and Installation Manual Single Action Model



(Double action model shown)

The Reduced Swing Doorset

The Reduced Swing Doorset Concept

The Ingersoll Rand Reduced Swing Doorset is a unique solution that has been designed to provide greater accessibility for people with impairments and to provide better utilisation of space.

So what makes the Reduced Swing Doorset so different?

Unlike a traditional door, the Reduced Swing Doorset is designed to be hinged at two points, and comprises of a two panel articulated door.

This unique design allows the door to fold in on itself in a concertina type action, and following an elliptical curve reduces the swing area to approximately 1/3rd that of a conventional door of the same width.

By reducing the swing area, accessibility for people with impairments is greatly improved, as the need to manoeuvre out of the way of the opening door leaf is eliminated. The design also results in a smoothness of operation that provides a greater ease of use.

Reducing the swing area also results in the more efficient use of both floor and wall space. A conventional door that opens onto a corridor or into a room requires the needed space taken up by the door width. By reducing the swing area, greater utilisation of space is achieved, as you only require space for 1/3rd of the door opening.

A conventional surface or cavity sliding door restricts the wall space to which fixtures can be mounted, however because the reduced swing door utilises a standard frame, the wall space either side of the doorset can be fully utilised.

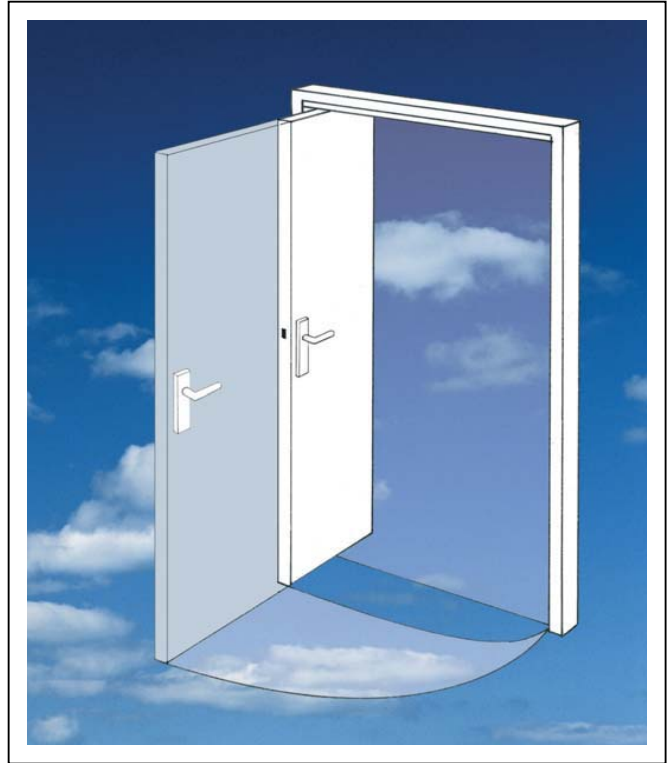

Illustrations showing conventional swing doorset compared to reduced swing doorset

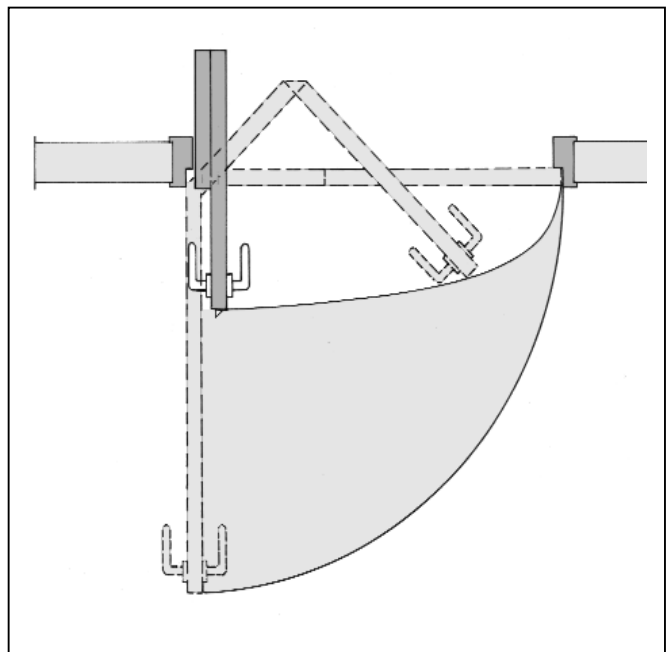

Single Action Features

Single Action

The simple single action doorset is ideal for confined areas and retro fitting into existing doorways used by people with physical impairments.

The single action doorset is a complete unit comprising a door frame, a two panel door leaf, operating gear and door hardware. The first panel of the door leaf is hung on a top and bottom pivot, whilst the action of the door is guided by a top pivot in the second leaf and a roller within the track at the head of the door frame.

The door hardware meets the requirements of NZS 4121:2001, and comprises of a Legge 990 series mortice lock/latch with corresponding Legge Alpha lever furniture (500, 700 or 800 series).

Specifications

- **Clear Opening:**
900mm (excluding door furniture projection)
1200mm clear opening available on request
- **Door Leaf:**
1980mm x 680mm/340mm as standard
Carbon Core as standard, Solid available
- **Door Jamb:**
Grooved or Architrave (finished to suit wall thickness)
- **Environment:**
Available as a 'Dry Area' unit or 'Wet Area' unit
- **Wall Cavity:**
Structural wall opening to be 10mm greater than trim size
- **Handing:**
Single Action Doorsets are supplied handed, refer handing details this page
- **Hardware:**
Legge Pacific 990 series mortice lock or latch with corresponding Legge Pacific Alpha lever furniture (500, 700 or 800 series).

(Measurements stated are indicative only)

Doorset Handing

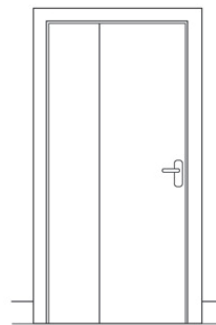
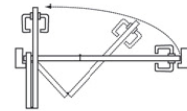

Left Hand

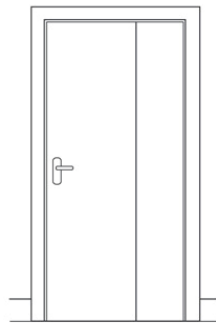
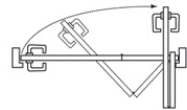

Right Hand

Guides

The sideways movement of the doors is guided by a roller that runs along an aluminium rail. Small enough to fit perfectly into the rebates of standard wooden or metal frames, you hardly know it is there

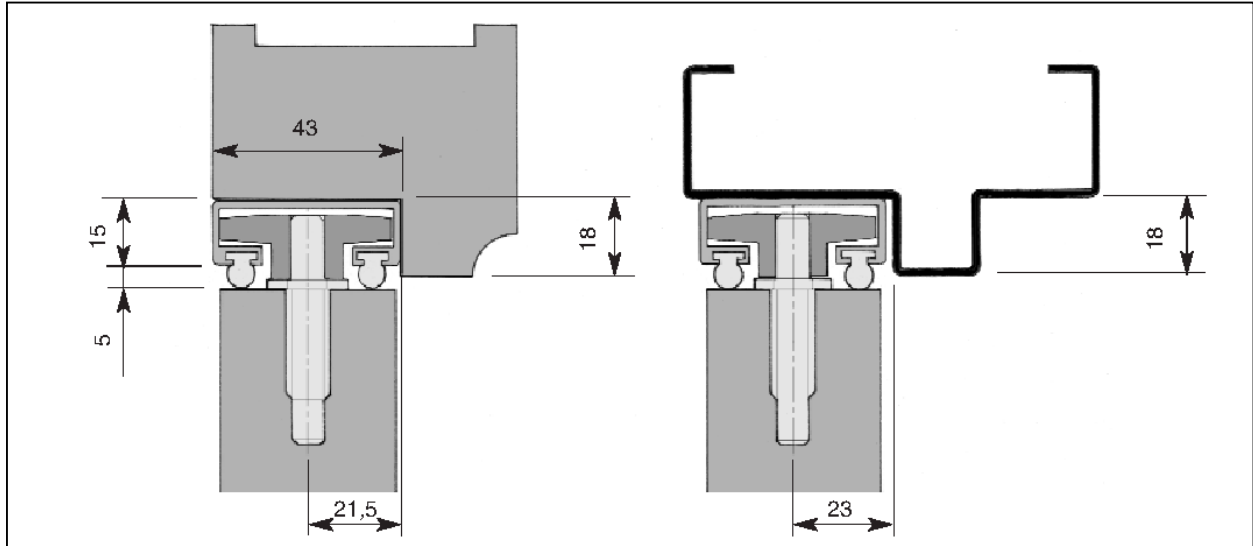

Adjusting the alignment of the leaves

The guide-wheel revolves round a 4 mm offset pin, positioned on the hinge at the upper edge of the door. This device makes it possible to adjust the alignment: If you rotate this pin towards the closure rebate, you can obtain a perfect alignment of the leaves when the door is closed.

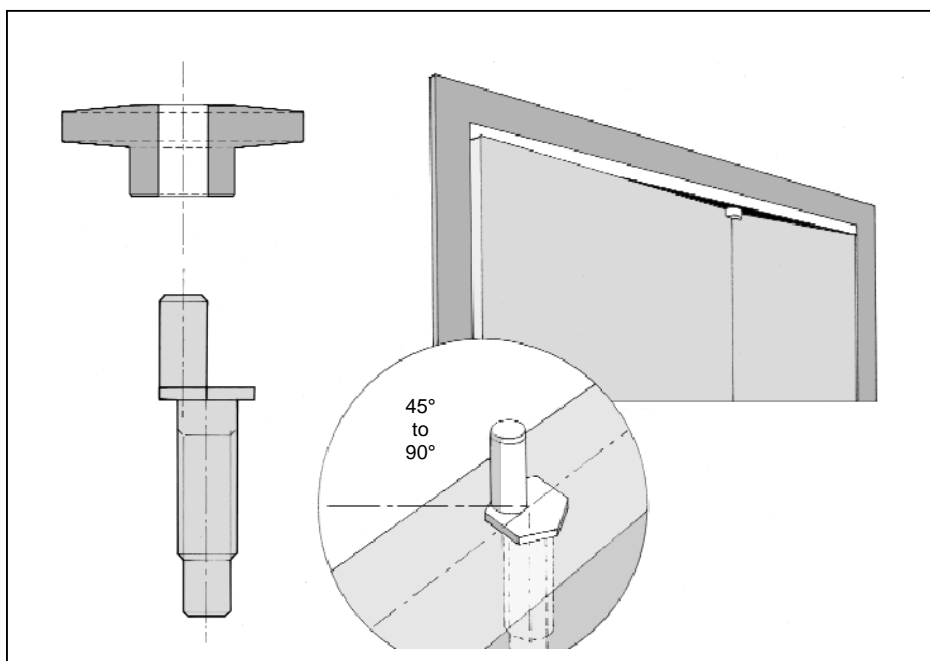

Top Pivots

Ingersoll Rand Reduced Swing Doors are mounted on two pivots top and bottom.

The top pivot is movable, so the door can be hung and removed easily, by simply pressing down a pin located on the edge of the smaller leaf (see fitting instructions).

Sideways adjustment is also possible to make up for any gaps, or frames out of true, by turning the nut behind the pivot socket (accessible when the door is removed).

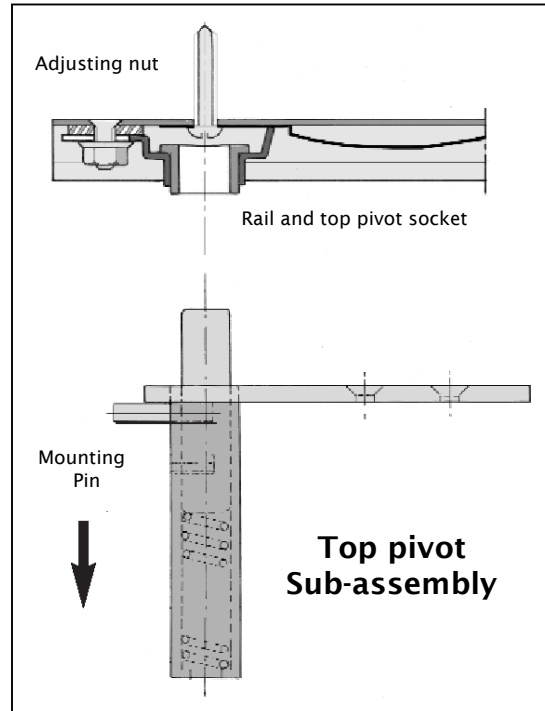
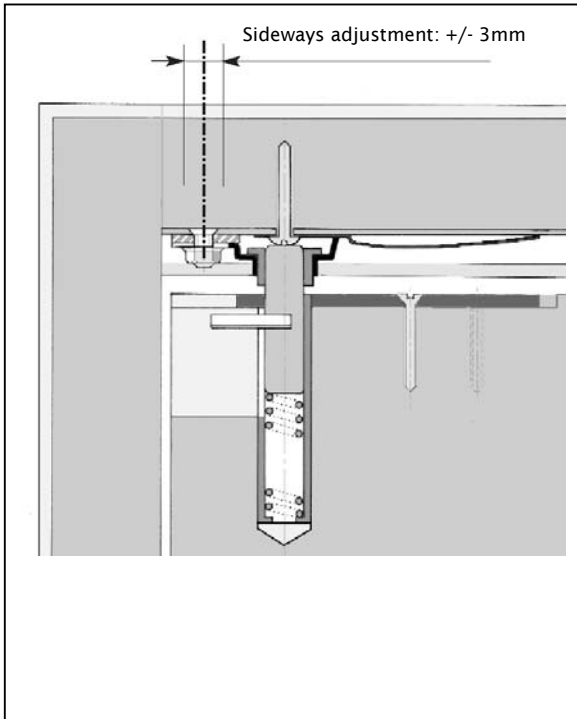

Bottom Pivots

The bottom pivot carries the weight of the door. It is fixed to the foot of the frame and must be fixed so that it rests on the floor (not inset into the floor).

It consists of self-lubricating parts that can be adjusted in height, width and thickness, to correct any faults of alignment. It is therefore important not to bury these adjustment parts in the floor covering, and to keep to the height of the bottom of the rebate.

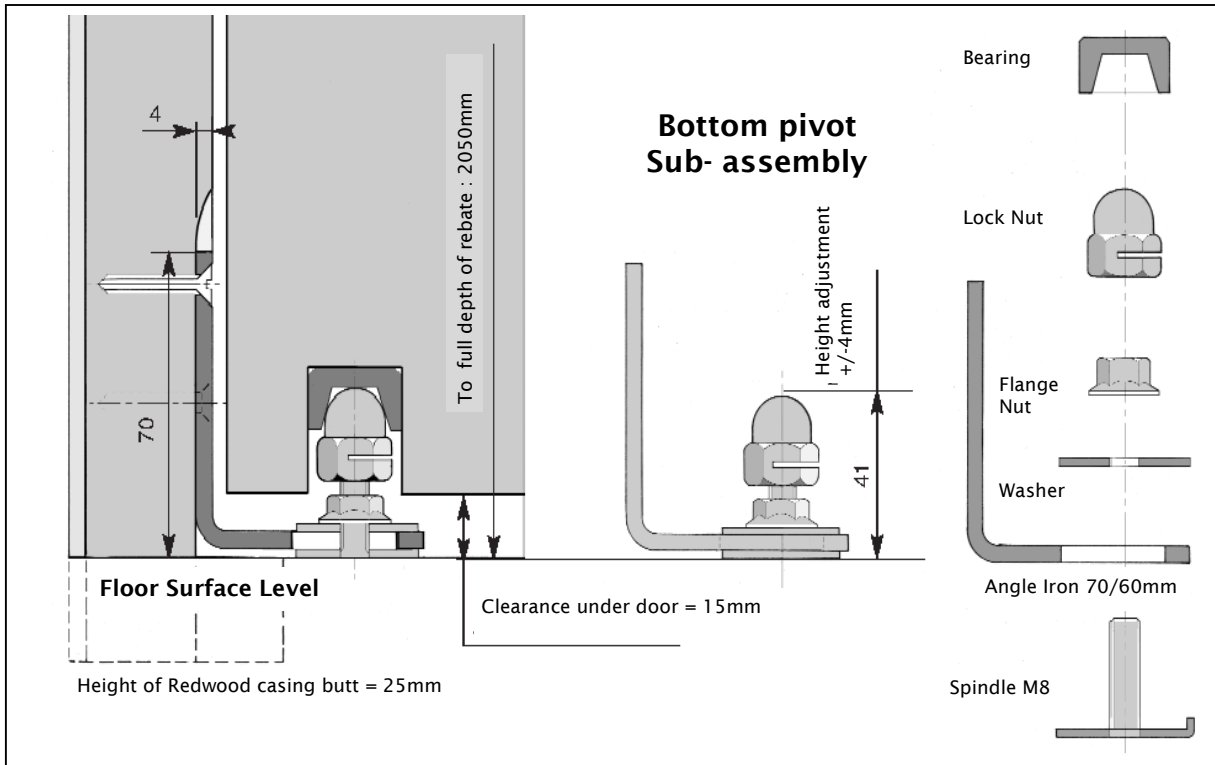

Bottom pivot on a metal frame

On a metal frame the bottom pivots are always machine screwed in the factory in advance. Alternatively they can be surface mounted on site, onto frames without hinge plates or punched holes, using self-tapping screws. (This method is not recommended - consult us.)

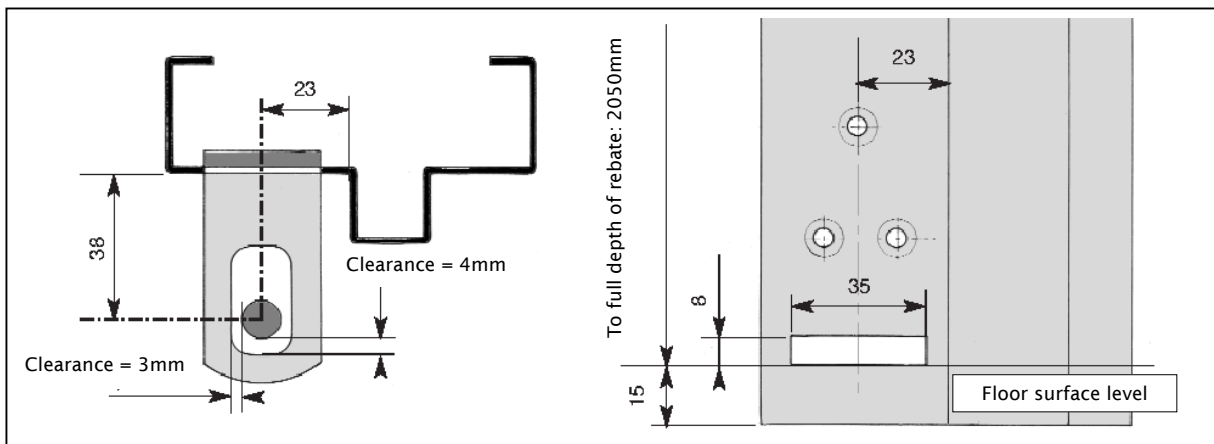

Fitting Instructions

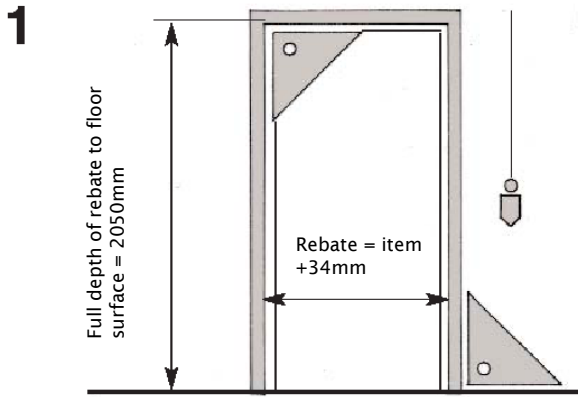

1 Preparing frames

True verticals and square corners are essential
(It is impossible to cut the single action doors)

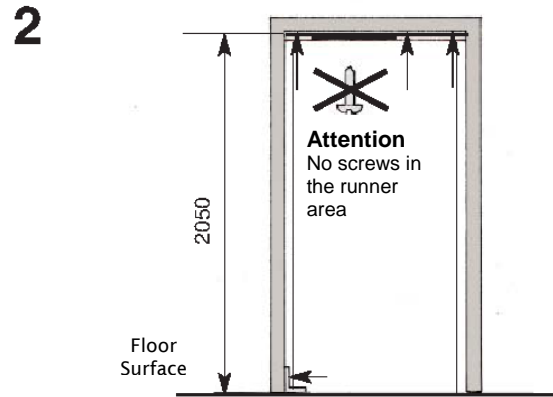

2 Fitting rail & bottom pivot

(For doors supplied with out frame)

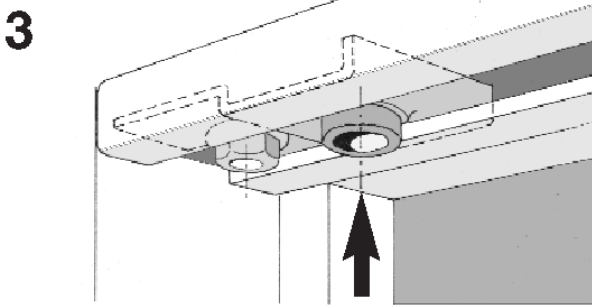

Wooden frames: screws VBA 5/30 TR
Metal frames: self-tapping screws 4/16 TR
Concrete casings: drill + masonry plugs

Fitting rail: use the pre-drilled holes
(No screws in the runner area.)

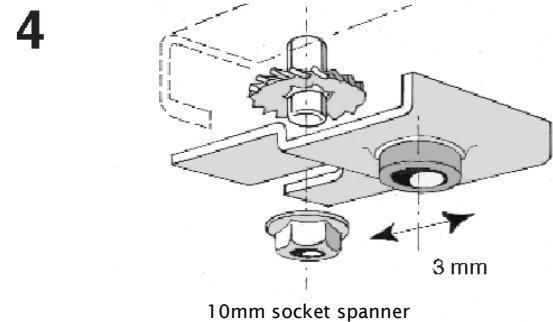

4 Adjusting the top pivot

ATTENTION:
If the fitting is dismantled, note carefully the order of components for reassembly

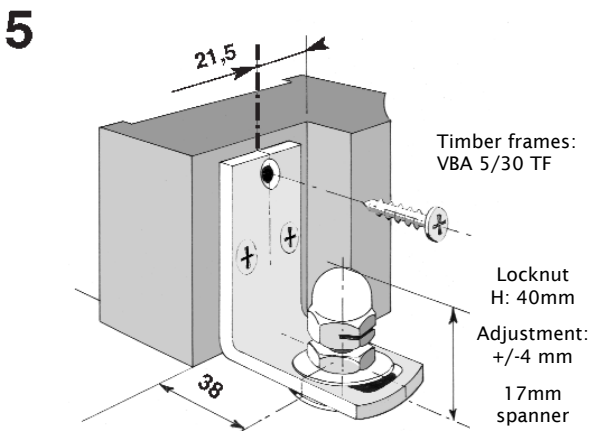

5 Fitting bottom pivot

Surface mounted: If door supplied without frame.

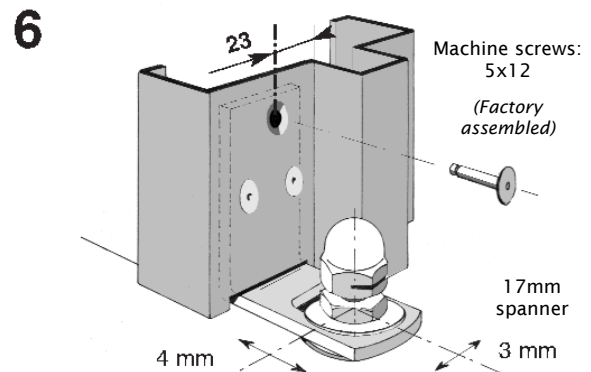

6 Sideways adjustment of bottom pivot

Fitted to metal frames: in factory = 5x12 metal thread screw
Flush mounted with pre-drilled holes: metal thread screws

7

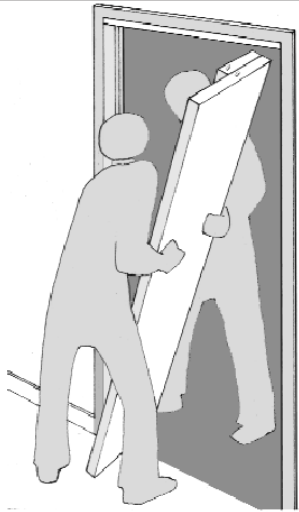

Place the folded door on the bottom pivot

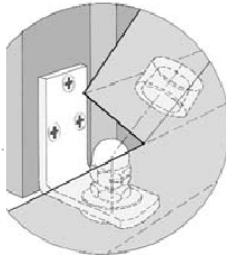

8

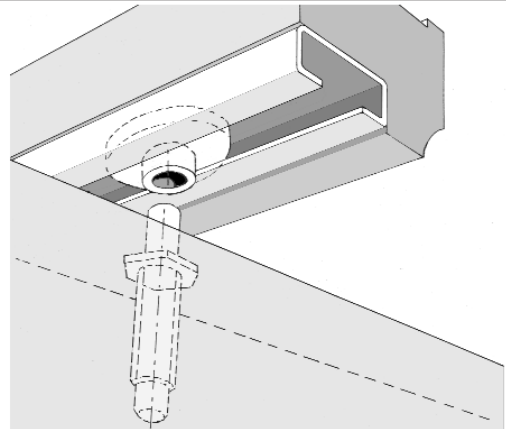

Engage the guide pin in the roller in the top rail, straighten the door up.

9

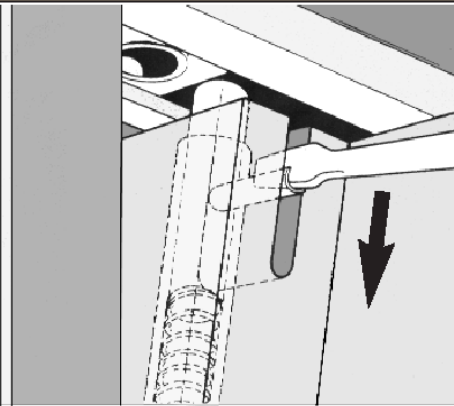

Engage the top pivot
Engage the top pivot in its socket by pressing the pin hard down.

10

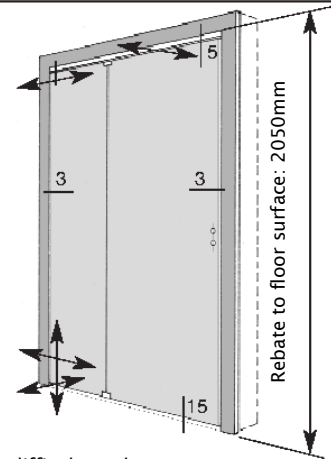

Adjust clearances

Attention: It is very difficult to plane or cut down single action doors.

11

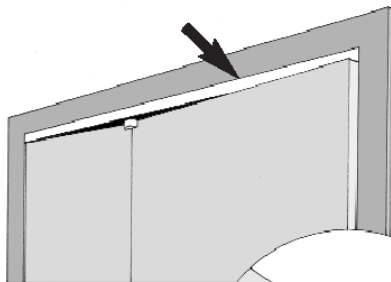

Align the leaves
If necessary, make corrections by turning the offset pin.

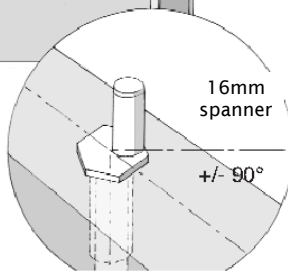

12

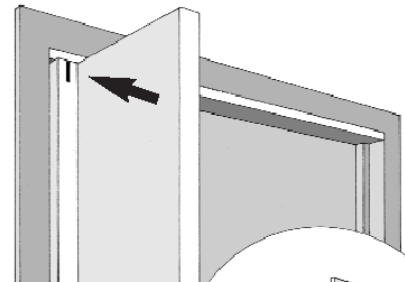

Locking the top pivot
After adjustment, press the shield into the pin slot.

