

DRILL FOR #10 SHEET METAL OR #10-24 MACHINE SCREWS (14 PLACES)

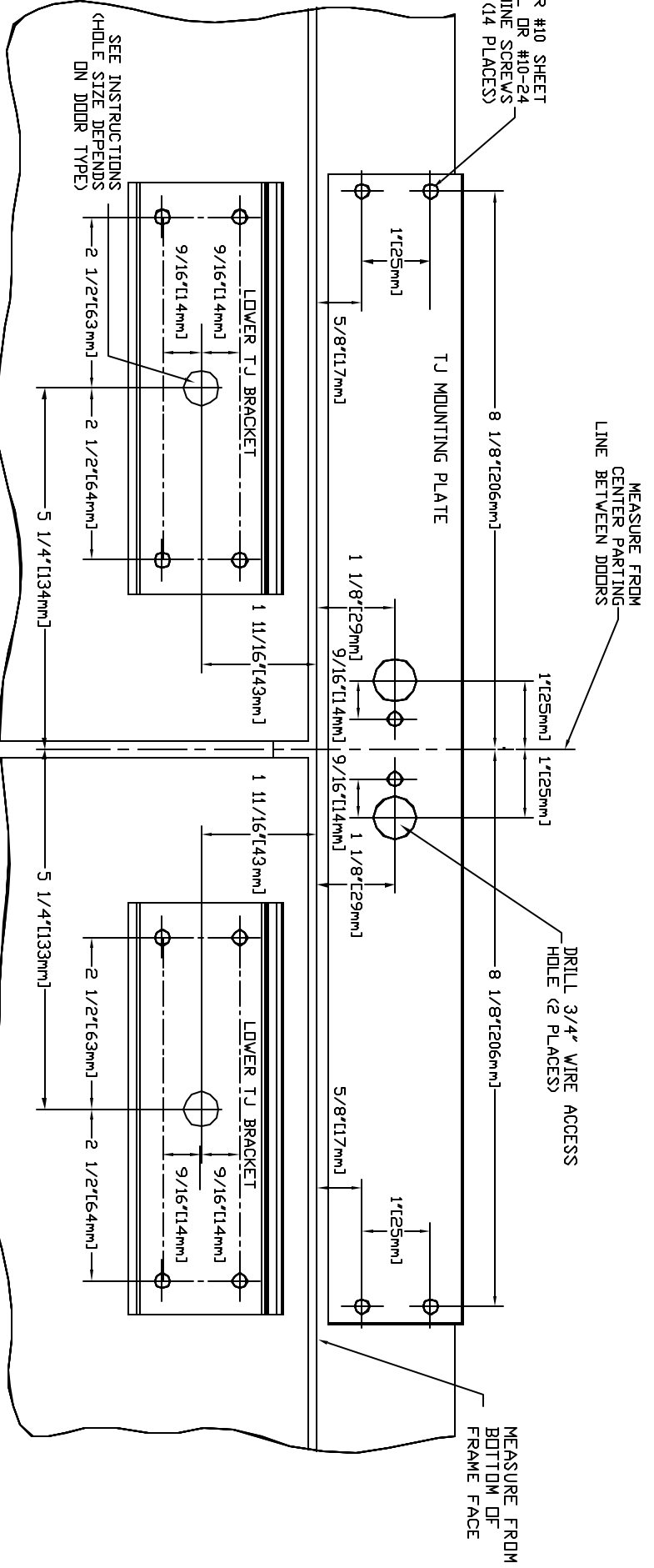

NOTES:

A variety of #10 fasteners is included in the hardware pack. Select the correct fasteners for the door and frame materials involved. For wood or hollow metal doors use self-tapping sheet metal screws for reinforced or heavy gauge metal doors and frames, use machine screws.

OVERALL DIMENSIONS:

TJ MOUNTING PLATE  
16 1/2"L x 2"H x 1/4" THICK

LOWER TJ BRACKET  
6"L x 2 1/4"H x 1/4" THICK

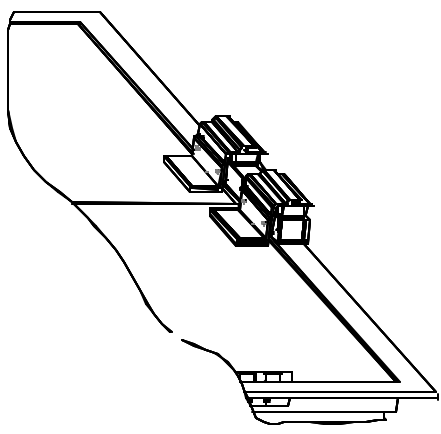

DRAWN BY: TG DATE 04-01  
CHKD BY:  
APP'D BY:

TITLE  
322+TJ22  
DOOR AND FRAME PREP

**LOCKNETICS**  
Security Engineering

FORM NO.  
322+TJ\_TMP

REV.  
B  
04-01